

NOTE:

- 1 - SEE ONE YEAR LIMITED WARRANTY FOR UNDERGROUND WATER TANKS.
- 2 - TANK USAGE: NON-POTABLE WATER STORAGE.
- 3 - INVERT DIMENSION FROM TANK I.D.

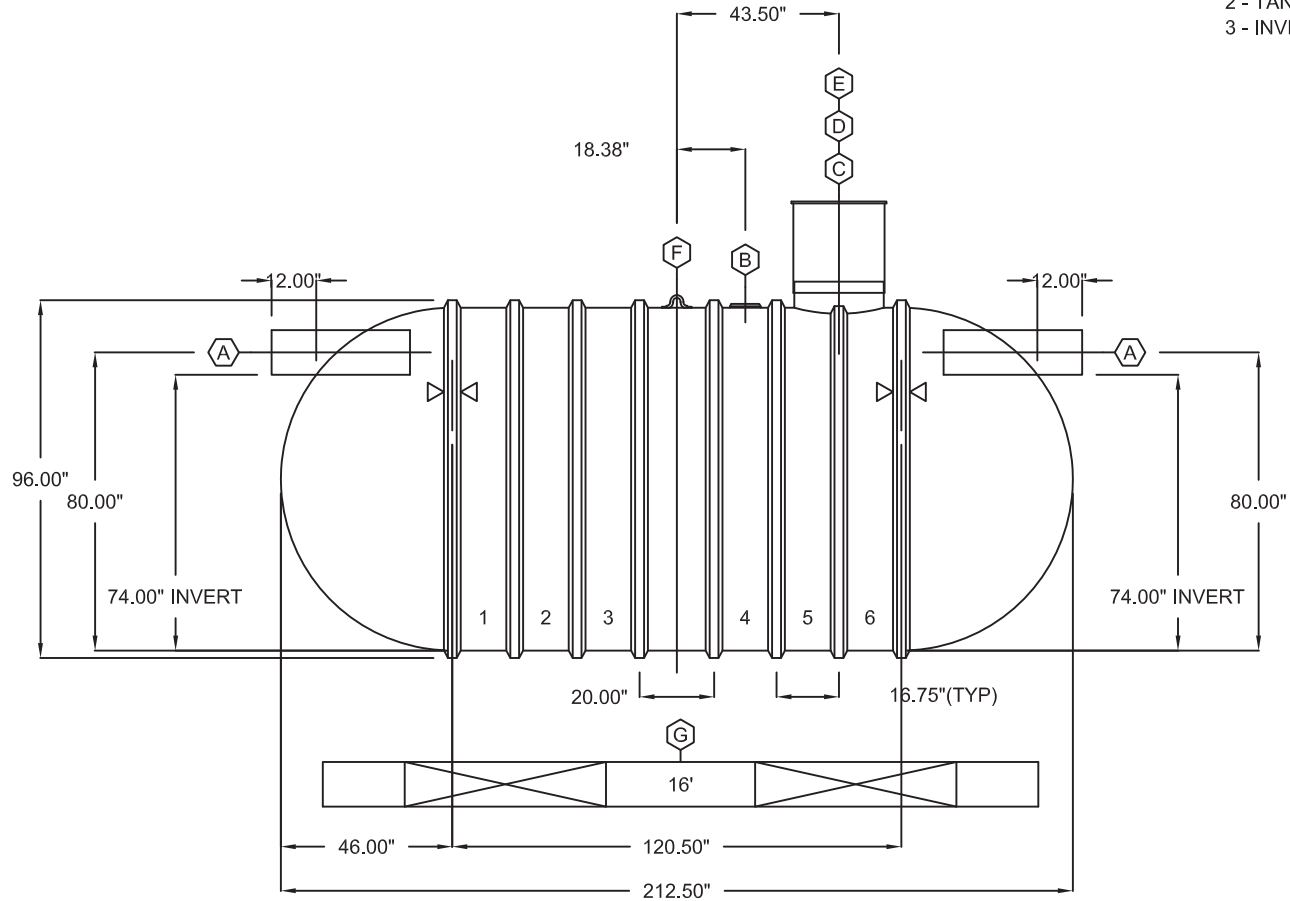

(A)	12"DIA SCH 40 PVC HORIZONTAL PIPE
(B)	6"NPT SERVICE FITTING
(C)	RISER PIPE, FOR 24"(NOMINAL) ACCESS OPENING
(D)	24"DIA x 24"HIGH FRP ACCESS RISER
(E)	24"DIA ORENCO LID WITH RISER-TO-LID ADAPTER
(F)	LIFTING LUG
(G)	16' PREFABRICATED CONCRETE DEADMEN (2 DEADMEN REQUIRED PER TANK)
(X)	HOLD DOWN STRAP LOCATION

**PROJECT: RAIN WATER HARVESTING FIBERGLASS STORAGE TANK
5000 GALLON MODEL WH2-8-5**

DRAWN: SFourmier	12/2010	DRAWING NO. File Name	
CHECK:		SIZE: A3	SCALE:
QUOTATION NO.*	DIMENSIONS IN: INCH		
SITEONE GREEN TECH - 888-438-7435			



TEL: (800) 427-0779 · FAX: (866) 477-9873
www.greentech.siteone.com

DO NOT SCALE DRAWING.