

PA4x-Series Pump Assemblies

The PA4x-Series Pre-Fabricated Pump Assemblies from **SiteOne Green Tech** offer unique features and benefits to the Commercial Landscape Irrigation Industry. PA4x-Series Pump Assemblies are available in suction lift, boost and flooded suction applications from 3 to 30HP with flows up to 500 GPM.

PREMIUM FEATURES

- Marine grade heated/insulated aluminum enclosure inhibits rust providing a robust design ensuring protection and security of all “under cover” connections, electrical disconnect and VFD. Package includes floor entry/exit intake and discharge piping configuration.
- Configure as a “complete control center” capable of housing pump[s], drive[s], SiteOne Green Tech's exclusive Rain Water Control Panel and GTV Series Automatic Self-Cleaning Filter.
- Victaulic galvanized pipe and connections eliminate leaks, welds, threads and unions simplifying field service.
- SiteOne Green Tech's 12 month limited warranty is backed by one of the industry's most experienced sales and service teams. SiteOne Green Tech also provides technical support, start-up and on-site field service for the life of your pump assembly.
- Variable Frequency Drive (VFD) is standard on all SiteOne Green Tech PA4x-Series pump assemblies. VFD is recommended for energy efficiency and soft start/stop to protect downstream pipe from damaging surges.



Only the highest quality, locally sourced components are used for maximum serviceability:

- Goulds Pumps
- Aluminum enclosure
- Siemens Disconnect
- CentriPro & Baldor Motors
- UL listed Drive Packages
- Victaulic Grooved Couplings
- Yaskawa IQ VFD with Pump Logic
- SiteOne Green Tech Filters & Flush Controllers

Standard Detail Drawings Available

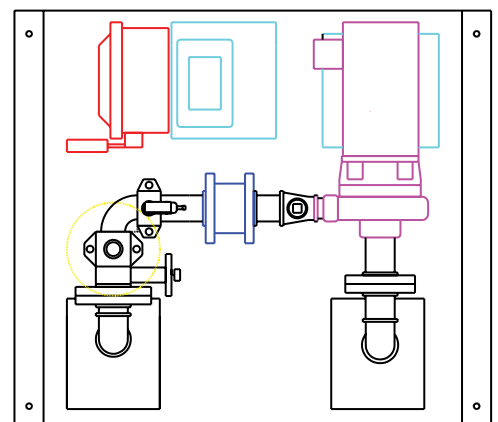

PA4x-Series Standard Features

- Marine Grade Aluminum Enclosure
- Nema 3R Electrical Enclosure
- UL Listed Drive Panel
- Integral "Under Cover"
- Service Disconnect
- ODP Electric Motor
- Lightning Protection
- Pressure Start
- Run Dry Protection
- Victaulic Piping
- Pressure Gauge
- Pressure Tank
- Isolation Valve

PA4x-Series Options

Motor Control Type

- Variable Frequency Drive [standard]
- Available Constant Speed

Voltage

- 208/3 Phase
- 230/1 Phase
- 230/3 Phase
- 460/3 Phase

Pump Start

- Pressure Start [standard]
- Relay Start
- Wireless Pump Start Relay
- Flow Start

Enclosure Finish

- Aluminum - No Powder Coat
- Powder Coat - Off White [Hammer Tone Texture]
- Powder Coat - Other Colors Available [Hammer Tone Texture]

Alarm

- Remote Monitoring Package
- Exterior Alarm Light

Enclosure Temperature Control

- Enclosure Fan for VFD [standard]
- Air Conditioner for VFD
- Freeze Protection

Noise Abatement

- Sound Attenuation

Automatic Filter & Controls

- Self-cleaning suction-scanning fine screen filter; available in powder coated carbon steel or stainless steel bodies
- Space restrictions limit availability on some models

Full Flow Bypass

- Space restrictions limit availability on some models

Engineered Intake System

- HDPE flange connected pipe and Sure-Flo self-cleaning suction strainer

Detail Drawings Available for Non-Standard models

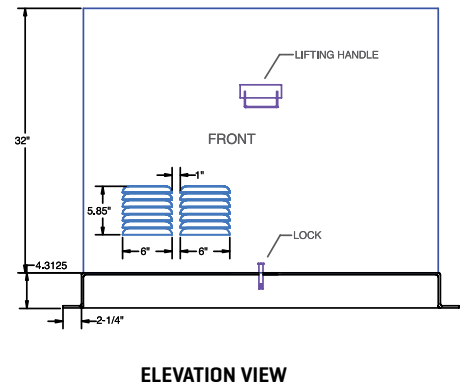
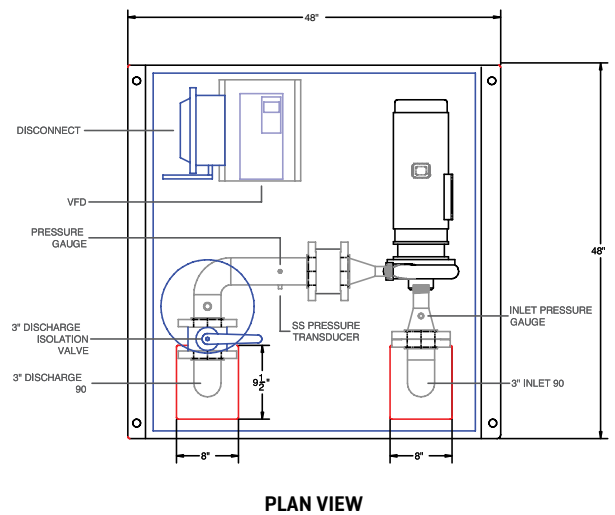

"Technology Solutions for the Green Industry"

800-427-0779

www.greentech.siteone.com